

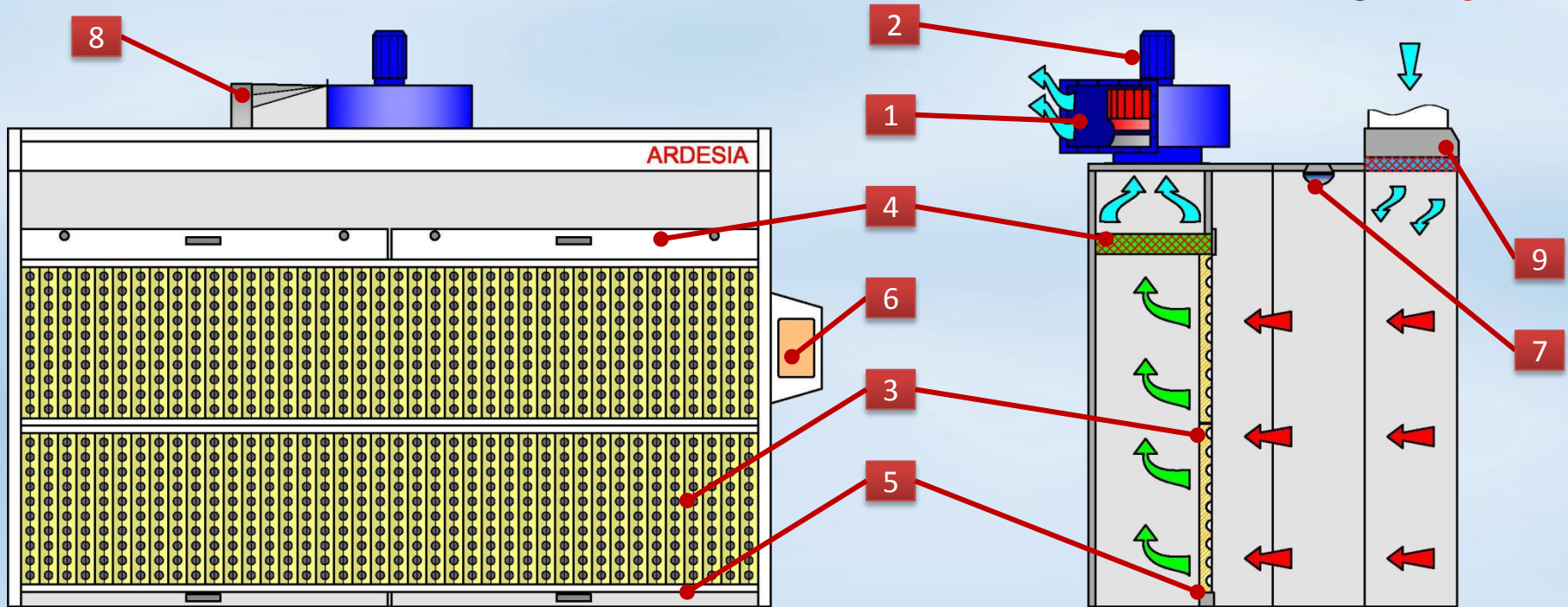

**ACTIVE SOLUTIONS BETWEEN  
INDUSTRY AND AMBIENCE**

**DESCRIPTION:**

This type of painting booth is suitable for suctioning and demolishing the pigments and fumes emitted from paint spray made with synthetic solvents, organic water. The removal of the pigments and fumes occurs with a suctioning wall of cardboard inertial and a second filtration with "Paint-Stop" filters drawers. The paint booth is built with modular panels of galvanized press folded sheet iron.

**EQUIPMENT:**

1. Antispark centrifugal electrical fan
2. Energy-saving electric motor IE2
3. Frontal cardboard inertial filters
4. Metallic drawers with "Paint-Stop" filter
5. Dust collecting drawers
6. Wired electrical panel IP 55 with timer
7. Wired ceiling light IP 65
8. Change section
9. Integrating air inlet filter (option)

# MODEL: SILVER

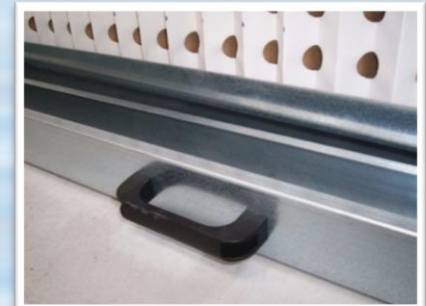
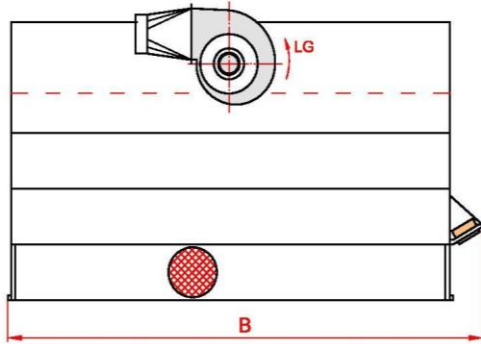
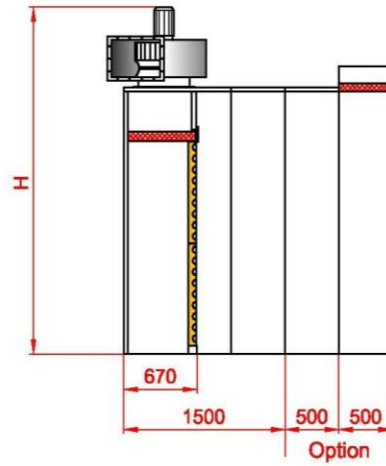
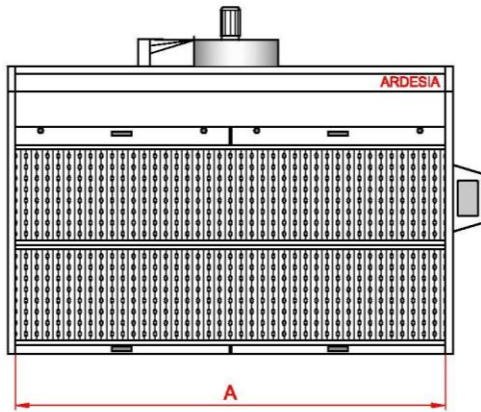

Model	A Usable width, mm	B Overall width, mm	H Overall height, mm	Illumination, N x Wt	Exhaust fan, power, kW	Nominal air flow m <sup>3</sup> / h
SILVER-2	2000	2450	3180	2 x 58	1,5	8000
SILVER-3	3000	3450	3250	2 x 58	2,2	11000
SILVER-4	4000	4450	3300	2 x 58	4,0	15000
SILVER-5	5000	5450	3250	4 x 58	2,2+2,2	22000
SILVER-6	6000	6450	3250	4 x 58	3,0+3,0	25000