

INTRODUCING VECTOR the new electrostatic spray gun range from the World leaders in electrostatic innovation.

RANSBURG engineers have reinvented the electrostatic spray gun by significantly improving paint atomisation, transfer efficiency, durability and operator comfort with greatly simplified controls. That's the new Vector - Improved from grip to tip!

VECTOR is the cost-effective solution for all low pressure electrostatic painting processes with complete compliance with European Environmental Legislation.

VECTOR provides considerable advantages compared to any other electrostatic spray gun system.

Aplicaciones características:

- General Metal spraying
- Intricate metal components and parts
- Commercial and off Road Vehicles
- Automobile Parts
- Aerospace industry
- Domestic Appliances
- Plus many others....



VECTOR

**Greater paint savings
with improved operator comfort**

- Superior atomisation and transfer efficiency
- Lighter weight with improved operator ergonomics
- Increased durability and reduced maintenance
- Redesigned electrostatic controllers - provide quick and simple operation
- Easy to clean and maintain.

Main advantages of VECTOR

The trigger pull force of VECTOR spray guns has been reduced by 50% and the dual stage air valve eliminates air to fluid transition.

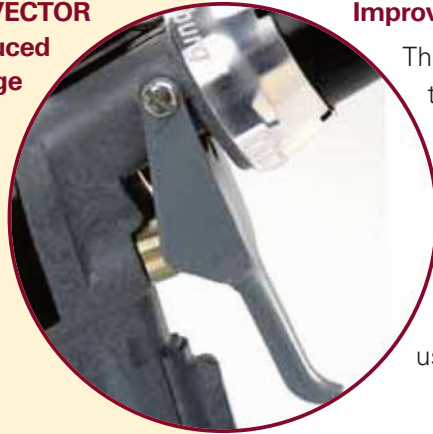

Improved ergonomics

The incredible reduction in weight has been achieved thanks not only to the light weight, stronger and more durable polymers used to manufacture VECTOR electrostatic spray guns, but also and by the redesign of the high-voltage cascade generator. The shifting of the centre of gravity, a slender, highly manoeuvrable design and soft trigger with adjustable finger grip ensure utmost user comfort.

VECTOR spray guns are equipped with pretested certified air caps, designed to deliver consistency, with the best quality atomisation. VECTOR is also fitted with a precision indexing fan air control valve for easy operation by both left and right hand operators.



Optimised atomisation and coating efficiency

The new Vector design redistributes the pressure in the air cap adjusting the balance between the atomization and fan air. This causes paint particles to move slower through the charging field which allows stronger charging and more paint delivered to the part with less overspray.

VECTOR cascade sprayguns incorporate 'triple set point' push button control putting unparalleled voltage control right at the users finger tips. This push button turns the voltage on and off and can also move between three 'pre set' voltage levels.



Improved Durability

VECTOR spray guns have 25% fewer components than other electrostatic spray guns. The design of the thread on the gun barrel is coarser for easy air cap and fluid tip removal while reducing the chance of cross-threading. All O-rings and seals are manufactured from Kalrez, a highly resistant material that extends Vectors lifespan.

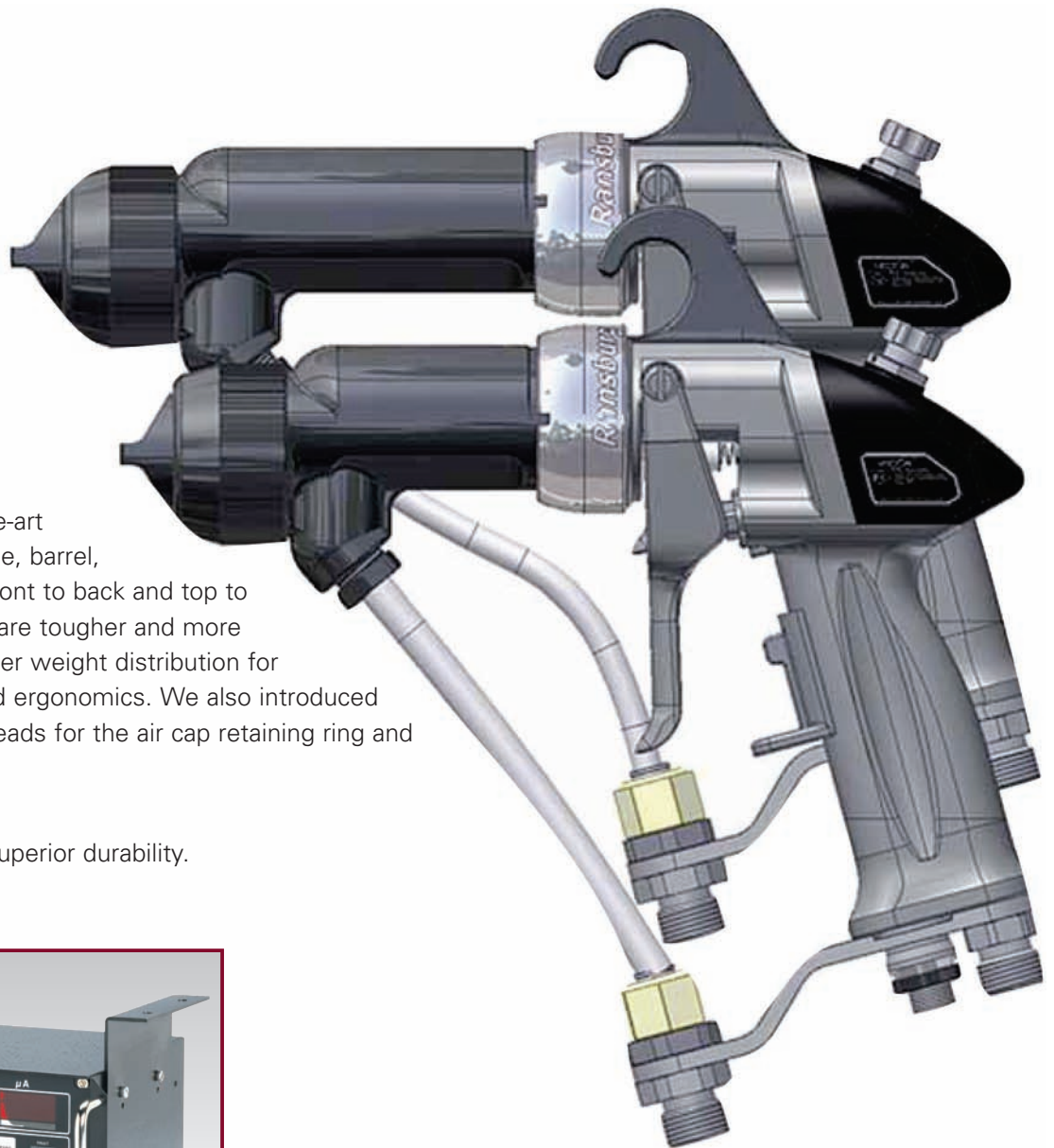

We utilize state-of-the-art materials in the handle, barrel, trigger and air cap. Front to back and top to bottom, Vector guns are tougher and more streamlined with better weight distribution for improved balance and ergonomics. We also introduced oversized, coarse threads for the air cap retaining ring and fluid tip.

The Result?

Easier cleaning and superior durability.



Improved electronic control

Vectors control unit offers the operator 'triple set point' voltage control, plus power on and off, right on the cascade gun. This microprocessor based control allows for data to be collected. This data can then be used to correlate the amount of paint used and parts painted.

The illuminated LED display on the control unit is visible at distances up to 15 metres. External controls can be connected via the integrated connection terminals.



Optional multi-position mounting brackets are available.

VECTOR

VECTOR options and accessories:

Options:

- Multi-position and mounting brackets
- High-conductivity material fluid tubes
- Two- or four-finger trigger
- Round or fan spraying

Accessories:

- Short stopper for high-conductivity coatings
- Air and fluid hoses
- Conductive gloves
- Spare parts kits
- Gun Covers

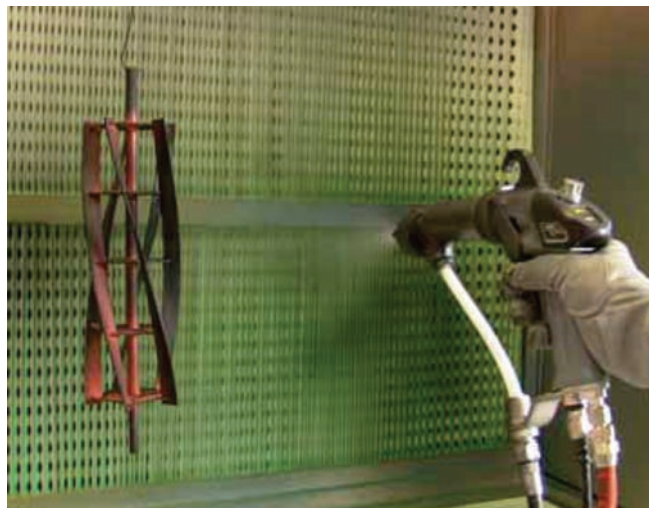

Example part order of VECTOR 90 Cascade (solvent based) with controller and 20 m low-voltage cable:

Order number: 79500 – **20 220 3**
 | Controller - 230V
 Cable length 20 metre

Technical data	VECTOR R 70 solvents		VECTOR R 90 solvents		VECTOR R 90 waterborne coatings	
	Classic ¹	Cascade ²	Classic ¹	Cascade ²	Classic ¹	Cascade ²
Spray gun model	Classic ¹	Cascade ²	Classic ¹	Cascade ²	Classic ¹	Cascade ²
Order number	79504	79501	79503	79500	79520	79523
Atomisation	Conventional	Conventional	Conventional	Conventional	Conventional	Conventional
Length	24 cm	24 cm	27 cm	27 cm	27 cm	27 cm
Weight	555 g	650 g	620 g	735 g	620 g	735 g
Operating pressure air/fluid	7 bar (100 psi)	7 bar (100 psi)	7 bar (100 psi)	7 bar (100 psi)	7 bar (100 psi)	7 bar (100 psi)
Tip voltage	65 kV	65 kV	85 kV	85 kV	85 kV	85 kV
Max current	140 µA	90 µA	140 µA	100 µA	140 µA	100 µA
Max fluid temperature	65° C	65° C	65° C	65° C	65° C	65° C
Max fluid delivery	1,000 ml/min	1,000 ml/min	1,000 ml/min	1,000 ml/min	1,000 ml/min	1,000 ml/min

high voltage supply ¹external / ²internal

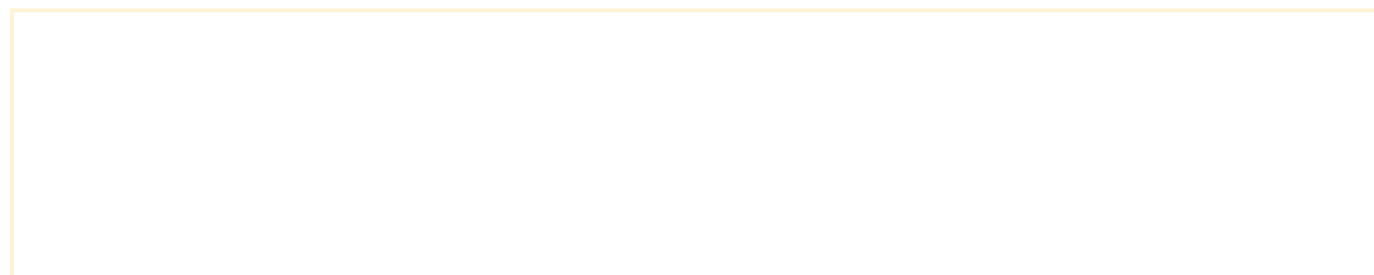

Finishing Brands (UK) Limited
 Ringwood Road, Bournemouth, Dorset
 England BH11 9LH
 Tel: +44 (0)1202 571111
 Fax: +44 (0) 1202 573488
 Email: marketing-uk@finishingbrands.eu

Finishing Brands Germany GmbH
 Justus-von-Liebig-Strasse 31,
 63128 Dietzenbach Germany
 Tel: +49 (0) 6074-403-233
 Fax: +49 (0) 6074-403-281
 Email: marketing-de@finishingbrands.eu

Surfaces et Finitions
 163-171 Avenue des Auréats, BP 1453
 26014 Valence cedex FRANCE
 Tel: +33(0)4 75 75 27 00
 Fax: +33(0)4 75 75 27 59
 Email: marketing-fr@finishingbrands.eu