



Spraypacks for finishing

HIGH PRESSURE PISTON PUMPS



- Outstanding durability
- Extremely high reliability
- Comfortable to handle

WAGNER Piston Pumps - They make the difference!

Quality makes the difference

Outstanding durability, high reliability and versatility, these are the characteristics of WAGNER finishing pumps. Our pumps are designed to satisfy any application requirement from the small workshop to the large industry. The new IceBreaker pump family keeps the old virtues of excellent usability and serviceability and combines them with new features that give users the comfort they want while keeping operating costs low.

1 IceBreaker

Exclusive IceBreaker technology distinguishes WAGNER pumps from all the others. Our air motor prevents ice accumulation inside the circuit ensuring consistent performance and great power under any working conditions.



2 Low pulsation

Thanks to the special packing-free, anti-stalling pilot valve WAGNER pumps run smooth and almost pulsation-free even at low working pressure.

3 Comfortable operation

The special integrated valve with one hand operation command makes the start-up of the pump extremely easy and smooth without adjusting the air pressure. The fluid circuit is operated from the front of the pump.

4 Ready for stroke sensor

The pump is ready to be equipped with a stroke meter. This enables the pump to be used on a TwinControl.

5 High safety standards

Special protection for the moving parts and integrated overpressure valve prevent risk of injuries to the operator.

CE Ex II 2G IIB T3

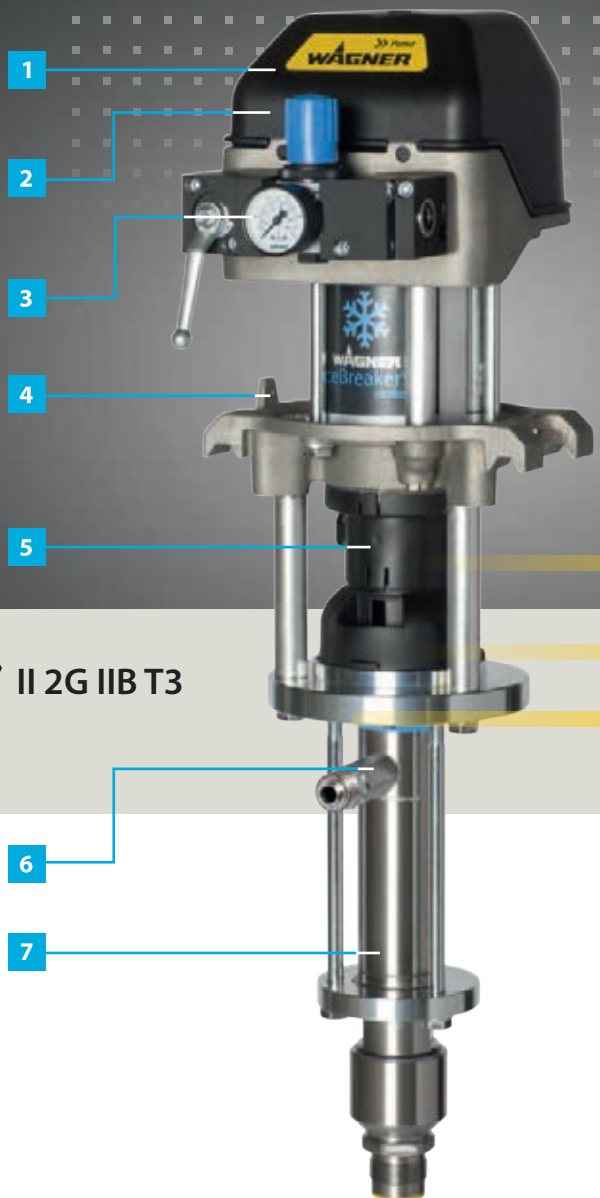

6 Versatility and durability

Stainless steel fluid section with special self adjusting packings, thick hard chrome plated piston and tungsten carbide valve seats ensure highest durability regardless of the material used. Perfect for water- and solvent based primers or top-coats.

7 Reduce service cost

Highly durable wearing parts and quick disassembly design makes service less frequent and very easy to execute.

Great advantages for different application methods

WAGNER finishing pumps: Designed for your needs!

For high quality coatings

AirCoat

WAGNER AirCoat manual or automatic guns combined with WAGNER pumps provide fast application with superior finishing quality, very high transfer efficiency and very comfortable working conditions.

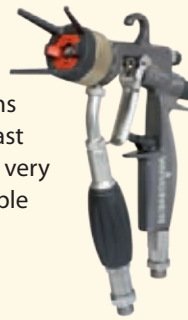

For higher transfer efficiency and top quality

Electrostatic

The new GM 5000AC in combination with an IceBreaker piston pump spraypack offers the highest level of transfer efficiency and surface quality. You can feel, see and measure the difference in surface accuracy and material savings.



For functional coatings

Airless

In combination with the well balanced fatigue-free WAGNER airless guns AG 14 or G 15 you will get outstanding performance durability and very productive application.



Complete product range to meet all application needs

Make your selection!

WAGNER IceBreaker® and EvoMotion piston pumps are the right choice for any kind of high pressure atomizing technology. They are readily equipped with all necessary connections and components for Airless or AirCoat applications. The huge range covers all application requirements.



Technical Data

Finishing Spraypacks - Overview

	AIRCOAT	AIRCOAT	AIRLESS	AIRCOAT	AIRCOAT	AIRCOAT	AIRCOAT	AIRCOAT	AIRCOAT
Technical Data	EvoMotion 20-30S	EvoMotion 40-15S		Wildcat 10-70	Puma 15-70	Puma 15-150	Wildcat 18-40	Leopard 18-300	Puma 21-110
Pump ratio	20:1	40:1		10:1	15:1	15:1	18:1	18:1	21:1
Max. working pressure [bar]	160	280		80	120	120	144	139	170
Double-stroke volume [cm ³ /DS]	30	14		70	70	150	40	300	110
Max. delivery rate [l/min]	1.8	8.4		4.2	4.2	9.0	2.4	18.0	6.6
Air pressure (max.) [bar]	8.0	7.0		8.0	8.0	8.0	8.0	7.7	8.0
Air supply	internal thread	8mm	8mm	G ½ "	G ½ "	G ½ "	G ½ "	G ½ "	G ½ "
Material inlet	external thread	M36x2	M36x2	M36x2	M36x2	M36x2	M36x2	M36x2	M36x2
Material outlet	external thread	¼"NPS	¼"NPS	M24x1,5	M24x1,5	M24x1,5	M24x1,5	M24x1,5	M24x1,5
Packing material	Standard Alternative	PE/T	PE/T	PE/TG PE/T	PE/TG PE/T	PE/TG PE/T	PE/TG PE/T	PE/TG PE/T	PE/TG PE/T

RANGE OVERVIEW

Search for the requested material flow and material pressure: Make your selection from 12 different pump models to find the exact solution for your job.

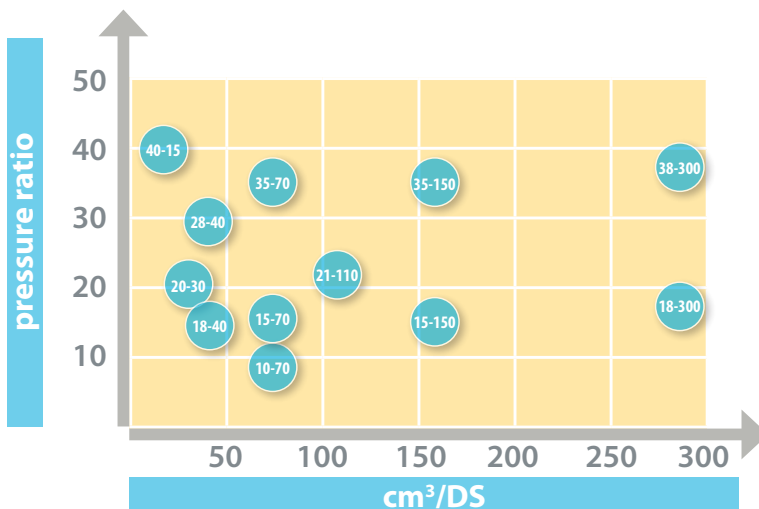

WETTED PARTS

- Tungsten carbide
- Stainless steel
- Hard chrome
- PTFE
- Packing material depending on pump type



Equipment for professional paint supply

Paint supply

WAGNER offers a complete range of components and accessories required in a comprehensive paint supply system. The WAGNER Accessory Catalog guides the user to the correct selection of parts such as system racks, agitators, elevators and material regulators plus the hoses and fittings to connect the components.

	AIRCOAT	AIRLESS	AIRCOAT	AIRLESS	AIRCOAT	AIRLESS	AIRCOAT	AIRLESS
Capacity	Puma 28-40	Leopard 35-70	Leopard 35-150	Jaguar 38-300				
Ratio	28:1	35:1	35:1	38:1				
Flow rate	224	249	270	270				
Pressure	40	70	150	300				
Flow rate (l/min)	2.4	4.2	9.0	18.0				
Flow rate (gpm)	8.0	7.1	7.7	7.1				
Thread	G ½ "	G ½ "	G ½ "	G 1"				
Mounting	M36x2	M36x2	M36x2	G 1½"-I				
Dimensions	M24x1,5	M24x1,5	M24x1,5	M24x1,5				
Material	PE/TG PE/T	PE/TG PE/T	PE/TG PE/T	PE/TG PE/T				

TYPICAL FLUIDS

- Solvent- and water based material
- 1-K and 2-K paint
- Primer and top coat
- Low-/ medium- / high solid material
- Paints and release agent
- PU and Epoxy material

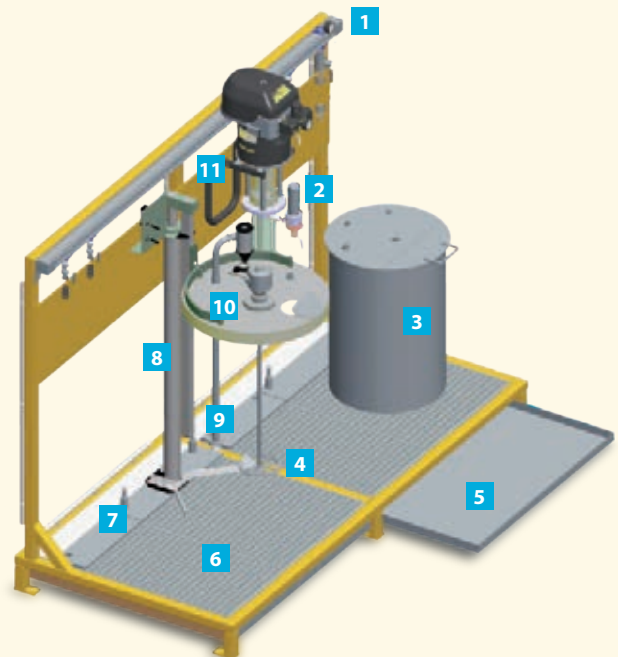

- | | |
|-------------------|--------------------|
| 1 Air supply | 7 Level monitoring |
| 2 Material filter | 8 Elevators |
| 3 Material box | 9 Suction systems |
| 4 Agitators | 10 Drum covers |
| 5 Drip trays | 11 Wall mounts |
| 6 Pump rack | |

Individual spraypacks and a wide range of accessories

Customized solutions

WAGNER offers a fully modular system which enables you to configure the spray pack to fit your application needs. Choose from 12 different pumps and then complete the package with your choice of up to 70 dedicated accessories.



1 Full range of spray guns

All WAGNER guns offer you the best ergonomics, highest reliability and unique features. Our latest developments include the new generation of GM 5000AC electrostatic guns for best performance in terms of finishing and transfer efficiency. The GM 4700AC manual AirCoat gun with patented "cage"-filter system guarantees long operation without interruption and best finishing results.

The most important part of a spray gun is the nozzle. WAGNER offers a wide range of high quality standard nozzles and special pre-atomizing nozzles. All WAGNER nozzles offer fast application speed, low overspray, high transfer efficiency with maximum application versatility and finishing quality.

2 Material hoses

Very flexible high pressure material hoses are a must for comfortable spraying operation. We offer a wide variety of hose packages ready for AirCoat or Airless applications.

3 Pump outlet

Need a filter or just a relief valve? Or do you need a complete circulation system? The modular system allows selection of just the accessories you need. Now available: The new WAGNER "cage"-filter as inline filter element.

4 Suction systems

Regardless of whether you need rigid suction pipe or an ultra-flexible suction hose – you can always find the right solution from our wide range of suction equipment.

5 Mounting equipment

Full range of mounting equipment available includes: Wall brackets, stands or big wheel trolleys.



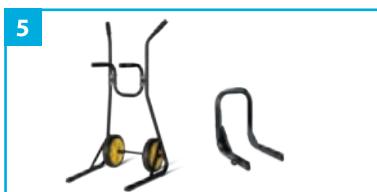

Cage Filter - capturing the dirt!

The new patented WAGNER Cage filter was designed by meeting customer's needs. With these needs in mind the filter was developed reducing dead spaces optimizing the flush ability, extending the lifetime and make it more compact to reduce the gun size and weight.

- Easy to exchange – clean filter housing
- Longer filter life time - bigger chamber for dirt
- Easy to flush - fast color change
- Easy to mount - can't be assembled wrong



A complete range of 2-K systems

WAGNER offers a wide range of 2-K systems. TwinControl - 1 color / 1 hardener / 1 solvent include all components required to mix the material. The FlexControl family offers additional features such as automatic color changes, recipe storage, peripheral equipment interfaces. Both are available for low and high pressure applications with a very high mixing accuracy.



HP diaphragm pumps

WAGNER Cobra®

WAGNER Cobra® is a high pressure double diaphragm pump suitable for AirCoat applications up to 250 bar. The pump is completely sealed from the external atmosphere. The absence of friction, the minimum of shear and almost no pulsation make it perfect for virtually any material and application! An extremely long lifetime guarantees a high process reliability. Suitable up to 5 l/min and ideal for water- and solvent based paints, UV and reactive materials.



www.wagner-group.com

Further information on WAGNER piston pumps and on a wide variety of accessories like suction systems, mounting equipment and fittings can be found in the WAGNER liquid applications catalog.

BASIC UNITS

Description		AirCoat	Airless	
Pumps				
	Piston pump EvoMotion 20-30 PE/T	■	□	2329452
	Piston pump EvoMotion 40-15 PE/T	■	■	2329450
	Piston pump Wildcat 10-70 PE/TG	■	□	2329460
	Piston pump Wildcat 10-70 PE/T	■	□	2329462
	Piston pump Puma 15-70 PE/TG	■	□	2329471
	Piston pump Puma 15-70 PE/T	■	□	2329473
	Piston pump Puma 15-150 PE/TG	■	□	2329475
	Piston pump Puma 15-150 PE/T	■	□	2329477
	Piston pump Wildcat 18-40 PE/TG	■	□	2329456
	Piston pump Wildcat 18-40 PE/T	■	□	2329458
	Piston pump Leopard 18-300 PE/TG	■	□	2329497
	Piston pump Leopard 18-300 PE/T	■	□	2329499
	Piston pump Puma 21-110 PE/TG	■	□	2329517
	Piston pump Puma 21-110 PE/T	■	□	2330614
	Piston pump Puma 28-40 PE/TG	■	■	2329467
	Piston pump Puma 28-40 PE/T	■	■	2329469
	Piston pump Leopard 35-70 PE/TG	■	■	2329479
	Piston pump Leopard 35-70 PE/T	■	■	2329481
	Piston pump Leopard 35-150 PE/TG	■	■	2329484
	Piston pump Leopard 35-150 PE/T	■	■	2329486
Piston pump Jaguar 38-300 PE/T	■	■	2329507	
Piston pump Jaguar 38-300 PE/TG	■	■	2329509	

ACCESSORIES

Description		Compatibility												
		EvoMotion 20-30	EvoMotion 40-15	Wildcat 10-70	Puma 15-70	Puma 15-150	Wildcat 18-40	Leopard 18-300	Puma 21-110	Puma 28-40	Leopard 35-70	Leopard 35-150	Jaguar 38-300	
Mounting Equipment														
	Wall mounting 4" cpl.	■	■	■	■	■	■	■	■	■				2332143
	Wall mounting 6" cpl.								■		■	■		2332145
	Wall mounting 9" cpl.												■	369020
	Stand 4" cpl.	■	■							■				2332374
	Trolley 4" cpl.	■	■	■	■	■	■		■	■				2325901
	Trolley 6" cpl.								■		■	■		2325916
	Trolley 4-wheels	■	■											T6196.00
Trolley Heavy Duty Leopard/Jaguar								■		■	■	■	369024	

ACCESSORIES

Description		Compatibility													
		EvoMotion 20-30	EvoMotion 40-15	Wildcat 10-70	Puma 15-70	Puma 15-150	Wildcat 18-40	Leopard 18-300	Puma 21-110	Puma 28-40	Leopard 35-70	Leopard 35-150	Jaguar 38-300		
Air Supply															
	AirCoat regulator cpl.			■	■	■	■	■	■	■	■	■	■	2328611	
	AirCoat filter regulator cpl.			■	■	■	■	■	■	■	■	■	■	2333478	
	Set AirCoat regulator	■	■											T6145.00A	
	AirCoat air shut-off valve	■	■	■	■	■	■	■	■	■	■	■	■	2338515	
	Lockable air supply mini			■	■	■	■		■	■				2334956	
	Lockable air supply midi								■			■	■	2334957	
	Lockable air supply maxi												■	2334958	
	Air-supply hose connector ½"			■	■	■	■	■	■	■	■	■	■	■	9985619
	Air-supply hose connector 1"													■	9985671
	Quickcoupling adaptor DN 13			■	■	■	■	■	■	■	■	■	■	■	9998813
	Quickcoupling adaptor DN 13 cpl.			■	■	■	■	■	■	■	■	■	■	■	322916
	Material Hoses														
AirCoat double hoses															
	AC-hose DN3 - 3,0m	■	■	■	■	■	■	■	■	■	■	■	■	2322656	
	AC-hose DN3 - 7,5m	■	■	■	■	■	■	■	■	■	■	■	■	2309705	
	AC-hose DN3 - 10m	■	■	■	■	■	■	■	■	■	■	■	■	9984596	
	AC-hose DN4 - 7,5m	■	■	■	■	■	■	■	■	■	■	■	■	■	2309706
	AC-hose DN4 - 10m	■	■	■	■	■	■	■	■	■	■	■	■	■	2312801
	AC-hose DN4 - 15m			■	■	■	■	■	■	■	■	■	■	■	2309634
	AC-hose DN4 - 20m			■	■	■	■	■	■	■	■	■	■	■	2309635
Airless single hoses															
	HP-hose DN3 - 3,0m	■	■	■	■	■	■	■	■	■	■	■	■	2323142	
	HP-hose DN3 - 7,5m	■	■	■	■	■	■	■	■	■	■	■	■	9984583	
	HP-hose DN4 - 7,5m	■	■	■	■	■	■	■	■	■	■	■	■	9984573	
	HP-hose DN4 - 10m	■	■	■	■	■	■	■	■	■	■	■	■	2302374	
	HP-hose DN6 - 10m	■	■	■	■	■	■	■	■	■	■	■	■	9984418	
	HP-hose DN10 - 15m			■	■	■	■	■	■	■	■	■	■	9984506	
	connection fitting			■	■	■	■	■	■	■	■	■	■	367561	
	HP-hose DN6-1,5m /fitting			■	■	■	■	■	■	■	■	■	■	9987117	
Material fittings															
	Fitting RF-FM G¼" - NPS ¼"-PN530-SSt													2332619	
	Fitting RF-FM G¾" - NPS ¾"-PN530-SSt													2332620	
	Fitting RF-FM G¾" - NPS ¼"-PN530-SSt													2332621	

For AirCoat and Airless guns see the related brochures and catalogues

